

Technical Data

Resistance at 0°C (R ₀)	1000 Ω		
Temperature coefficient (0°C up to +100°C)	3.85 · 10 ⁻³ K ⁻¹		
Tolerance classes according to DIN EN 60751	<ul style="list-style-type: none"> • F 0,1 (0°C - +150°C) • F 0,15 (-30°C - +300°C) • F 0,3 (-50°C - +500°C) 		
Operating temperature range depending on lead material:			
AgPd5, Au-coated Ni-wire	-50 °C up to +400 °C		
Pt-coated Ni-wire	-50 °C up to +500 °C (short-time up to +550 °C)		
AuPd5, Pt	-50 °C up to +600 °C		
Measurement current (DC) at 25 °C	0.1 mA		
Maximal permissible peak current (DC) at 25 °C	0.3 mA		
Insulation resistance	> 10 MΩ		
Self-heating at 0 °C	< 0.5 K / mW		
Thermal response time			
Flowing water (v = 0.2 m/s)	T _{0,5} = 0.07s, T _{0,9} = 0.2s		
Flowing air (v = 1 m/s)	T _{0,5} = 4 s, T _{0,9} = 10 s		
Resistance value [Ω] at			
Temperature	Tolerance class		
	F 0,1 [Ω]	F 0,15 [Ω]	F 0,3 [Ω]
0 °C	1000 ± 0.4	1000 ± 0.6	1000 ± 1.2
+100 °C	1385.1 ± 1	1385.1 ± 1.3	1385.1 ± 3

R _t measuring point	2 mm from wire end
Maximal Resistance Change at UCT 250 h	< 0.1 %
Specification	DIN EN 60751
Type	Film sensor

Technology: Advanced thin-film-technology (ceramic carrier with a structured platinum layer, covered with a passivating layer)

Operating conditions: Unprotected application only in dry environments without any contamination

Conformity: 2011/65/EU: Restriction of the use of Hazardous Substances Directive (RoHS)

Dimensions [mm]

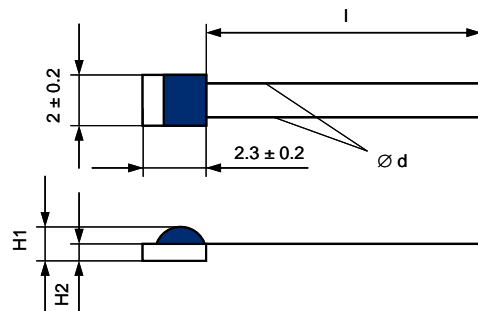

	FMC2145 2x2.3x1.3	FMC2145 2x2.3x1.0	Leads	AgPd5	Ni	NiAu	NiPt	AuPd5	Pt
H1 [mm]	1.3 ± 0.2	1 ± 0.2	l [mm]	15 ± 1	15 ± 1	15 ± 1	10 ± 1	10 ± 1	7 ± 1
H2 [mm]	0.65	0.4	d [mm]	0.25	0.2	0.2	0.2	0.25	0.2

Functional performance

according to DIN EN 60751

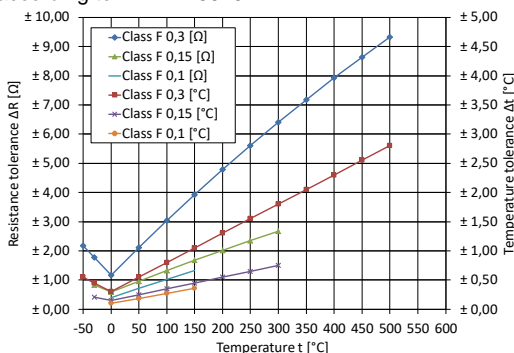

Picture 1: Resistance and temperature tolerances of Pt1000 (Please note - the operating temperature range depends on lead material!)

Temperature range from -50 °C up to 0 °C:

$$R_t = R_0 \cdot (1 + A \cdot t + B \cdot t^2 + C \cdot (t - 100 \text{ °C}) \cdot t^3)$$

Temperature range from 0°C up to +600°C:

$$R_t = R_0 \cdot (1 + A \cdot t + B \cdot t^2)$$

Tolerance classes according to DIN EN 60751:

Class F 0,1 (0°C - +150°C): $\Delta t = \pm (0.1 + 0.0017 \cdot |t|)$

Class F 0,15 (-30°C - +300°C): $\Delta t = \pm (0.15 + 0.002 \cdot |t|)$

Class F 0,3 (-50°C - +500°C): $\Delta t = \pm (0.3 + 0.005 \cdot |t|)$

Whereby:

R_t ... Resistance [Ω] at temperature t

R₀ ... Resistance [Ω] at 0 °C

t ... Temperature [°C]

Δt ... Permissible temperature deviation at t [°C]

$$A = 3.9083 \cdot 10^{-3} \text{ °C}^{-1}$$

$$B = -5.775 \cdot 10^{-7} \text{ °C}^{-2}$$

$$C = -4.183 \cdot 10^{-12} \text{ °C}^{-4}$$

Fields of application

- Industrial electronics
- Building automation
- Automotive electronics
- Energy and environmental engineering
- Safety and medical engineering

Ordering examples

Construction	Class of accuracy	Leads (ø d x l [mm] lead material)	Operating temperature range [°C]
FMC 2145 2x2,3x1.3	F 0,15	0.25x15 AgPd5	-50/+400
FMC 2145 2x2,3x1.0	F 0,3	0.2x10 NiPt	-50/+500

Other classes of accuracy and wire lengths are available on request.